

MADE IN ITALY



Direct driven
rotary screw compressors
with vertical arrangement
and variable speed with
HDPM permanent magnet motor

NOBEL V

18.5-90 kW



VERTICAL
NEW RANGE 2025

FNA Compressors

Over 75 years of compressed air.

FNA is a Multinational Group with over 75 years of experience in the compressed air sector, founded from the merger of three great Italian compressor traditions, which has developed an industrial synergy capable of competing on the world market without fear of comparison. Thanks to the consolidated experience and leadership of a family that has been operating exclusively in the compressed air sector for two generations, since 1948, FNA is one of the leading manufacturers of air compressors for industrial, professional and consumer use.

Today, Power System is part of the FNA family and is the Groups brand that represents the pinnacle of our technology, aimed specifically at the Industrial market. Power System is an undisputed leader in the design, development, production and distribution of high-tech solutions for compressing air with the greatest possible energy savings, serving every sector, from large industry to small business.

Power System's screw compressors, in the 2.2 to 315 kW power range, are manufactured entirely in Italy in the province of Bologna, an area renowned for its excellence in precision engineering, where the most modern design, construction, assembly and testing technologies are applied to ensure customers reliable compressors with first-class performance.



TORINO
ITALY

Production sites around the world

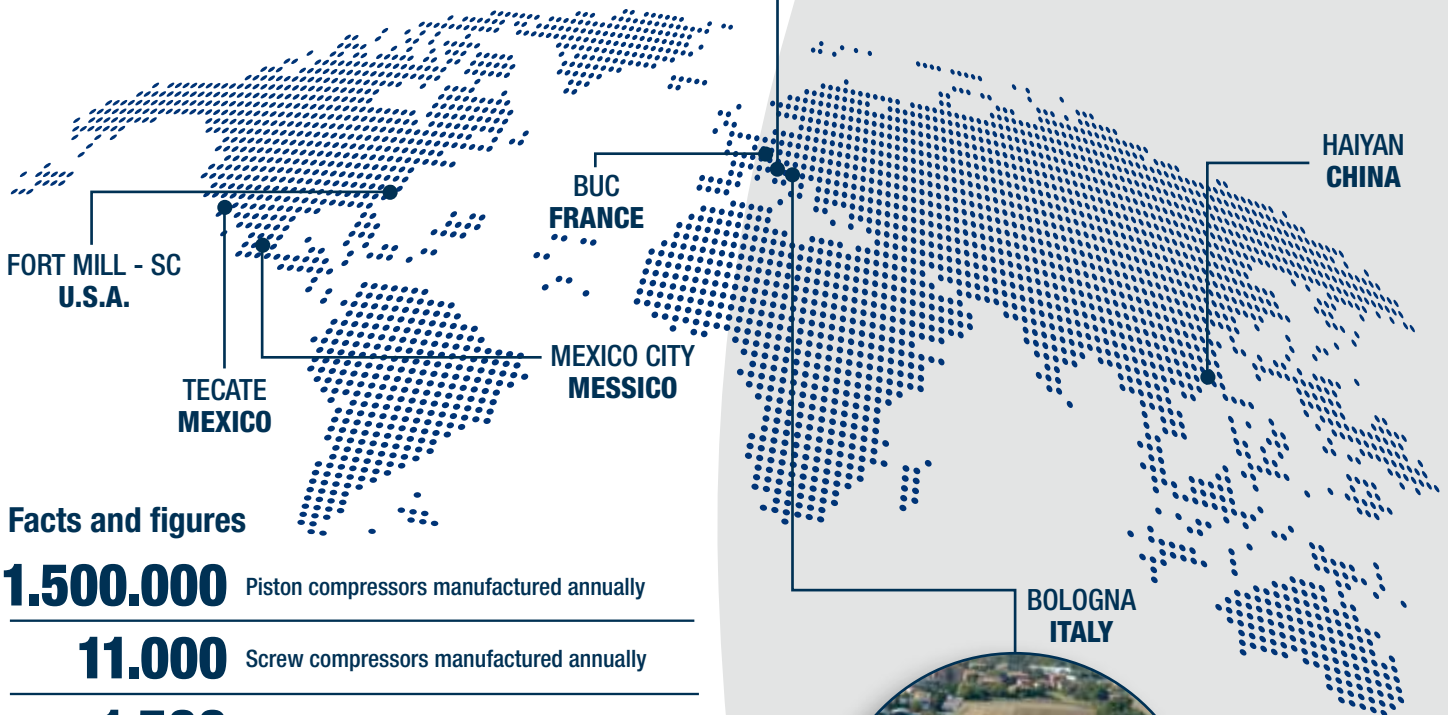

Facts and figures

1.500.000 Piston compressors manufactured annually

11.000 Screw compressors manufactured annually

1.500 Global service centres

1.300 Employees

250 Million € turnover

120 The countries we export to

7 Production plants worldwide



BOLOGNA
ITALY

The Power System brand

Manufacturers of air-ends for over 30 years.

Power System is the leading Italian company, that has been able to combine craftsmanship with the most modern industrial technologies and highly specialised labour. The Made in Italy trademark is the expression of typical Italian quality and creativity, recognised and appreciated around the world, and which is now one of the distinguishing elements of our industrial production.

What makes Power System screw compressors unique is the guarantee of a product that is made entirely in Italy: from design to packaging, each stage of production is carefully overseen by our engineers and aimed at developing a machine that exceeds the most demanding requirements in terms of efficiency, quality, energy saving, performance, quiet and safe operation. Each component is thoroughly selected to integrate perfectly with our air-ends and intake regulators.

Power System air-ends feature rotors with an optimised profile and outstanding performance. The production process is completely integrated thanks to avant-garde machine tools with robotic component positioning and sophisticated control instrumentation that guarantees the highest level of quality. Each single rotor is cut in four very specific manufacturing stages to achieve high precision, execution and repeatability.

Before reaching the customer, every individual compressor is fully tested before completing final checks that ensure total compliance with over fifty stringent technical requirements.

Since 1996, the company's Quality System has been certified according to UNI EN ISO 9001:2015.



NOBEL V

The Vertical solution to compressed air demands.



High efficiency and energy saving

NOBEL V compressors have been designed to combine all the best components current technology has to offer in a single compressor in order to achieve maximum operating efficiency.

In particular, the high power density HDPM electric motors, with efficiency class IE5, offer **outstanding efficiency** in extremely compact dimensions and very low operating temperatures.



LOGIN Controller

All NOBEL V models are equipped with Login electronic controller with touch-screen display. In addition to complete control of all compressor functions, it allows data to be stored on a memory card, enables multi-compressor management (up to 8 units, even of different types) and remote control via SMS 2.0 device.



Quiet operation

Thanks to low-speed air-ends and the use of inverter-controlled radial fans, which modulate their speed according to the operating temperature, the NOBEL V series ensures quiet, best-in-class operation.



Compact and vertical design

In addition to the vertical mounting of the motor air-end system, the entire combination of components and the choice of their positioning has made it possible to reduce both the footprint of the machine and the total space including that required for maintenance.



Simplified maintenance

Large panels allow easy and immediate access to all parts subject to routine maintenance. Up to the 50 kW model, maintenance can also be performed only from the front, which is why the overall dimensions, including maintenance, are among the lowest in its class.



Remote monitoring and preventive maintenance

The optional SMS 2.0 system allows remote control of the compressor and promptly informs the user or service centre of the machine's status, signalling any alarms or the need for maintenance work.



An innovative range from 18.5 to 90 kW, also in TWIN configuration.

| Size | Power (kW) | Model | Configuration | Air-end | Electronic controller | Variable speed with Permanent Magnet Motor / Electric motor efficiency |
|------|------------|-----------------|---------------|-----------|-----------------------|--|
| 1 | 18.5 | NOBEL V 18.5 PM | SINGLE | FS140 | Login | HDPM / IE5 |
| | 22 | NOBEL V 22 PM | | | | |
| | 26 | NOBEL V 26 PM | | | | |
| 2 | 30 | NOBEL V 30 PM | | FS270 | | |
| | 37 | NOBEL V 37 PM | | | | |
| | 45 | NOBEL V 45 PM | | | | |
| 3 | 50 | NOBEL V 50 PM | TWIN | 2 x FS140 | | |
| | 55 | NOBEL V 55 PM | | 2 x FS270 | | |
| | 75 | NOBEL V 75 PM | | | | |
| | 90 | NOBEL V 90 PM | | | | |



+

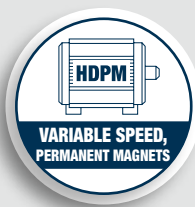

+



+



+



+



The most flexible Nobel ever!

Power System once again redefines the efficiency and configuration standards for screw compressors: the NOBEL V series features the motor air-end assembled firmly with vertical axis, with 1:1 coaxial transmission.

The TWIN versions, starting from 55 kW, are equipped with two compressor systems, integrated in one cabinet. This innovative solution expands operational flexibility, with **control ranging from 3.8% to 100% capacity**, ensuring optimal efficiency even in the most variable conditions.

The combination of high-performance Power System air-ends with High Density Permanent Magnet motors (HDPM) configures the NOBEL V as extremely compact, efficient and quiet machines.

NOBEL V

22-50 kW

With its NOBEL V series Power System once again demonstrates how innovation, efficiency, energy saving, reliability, quiet operation and practicality can converge in a single machine, offering state-of-the-art technical solutions.

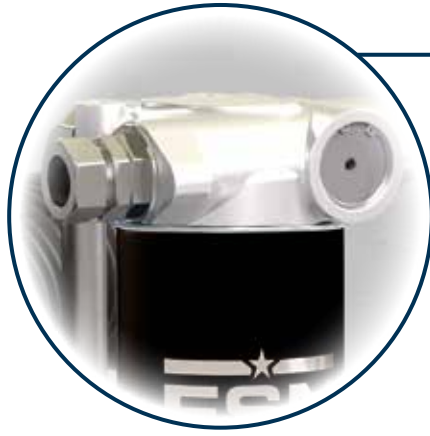

Thermostatic valve

It controls the oil flow by preventing sudden temperature changes and prevents condensation inside the lubrication circuit.

Pre-filtering panel

The ventilation circuit is completed by a pre-filtering panel that separates incoming dust, protecting internal components for a longer service life.



Minimum pressure valve

It guarantees reduced pressure losses and reduces energy consumption.

Direct coaxial 1:1 transmission with vertical set-up

No losses, maximum efficiency. The NOBEL V series is equipped with HDPM permanent magnet motors with unique characteristics, air-cooled and characterised by high power density (High Density Permanent Magnet).

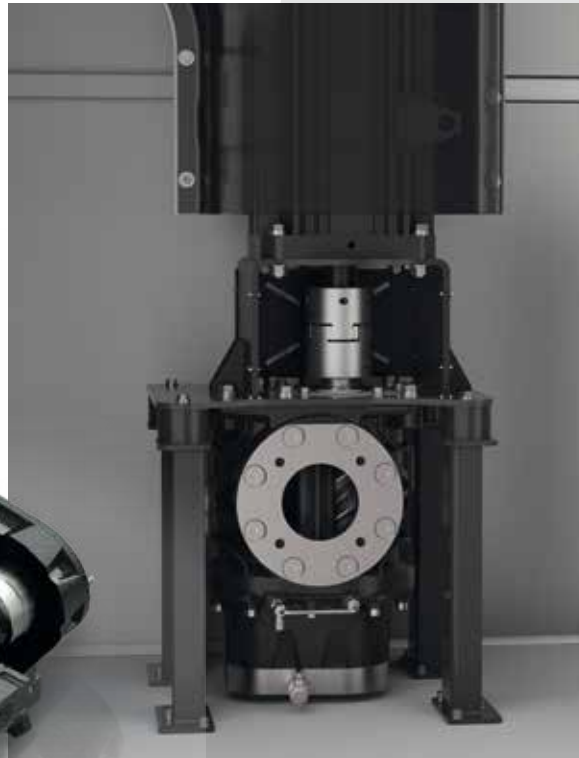

Air-end FS140



Easily removable flexible coupling.

Quiet ventilation

Extremely quiet operation due to inverter-controlled radial ventilation, set on operating temperature control. Starting with the 45 kW model, the inverter is integrated in the fan motor.

Air filter

Highly efficient intake filter operation with easily accessible and replaceable cartridge.



LOGIN Controller

Simple and intuitive, powerful and flexible programming. For remote control and multi-compressor management. Designed for Industry 4.0.



Intake regulator

It guarantees maximum efficiency, low noise and high reliability.

Inverter

Combined with HDPM permanent magnet motors, it ensures operating stability, maximum efficiency and a long service life.



NOBEL V 45

The door on the front allows the oil level to be quickly inspected without having to open the machine.

NOBEL V - Twin

55-90 kW

The technical choice of installing two technically independent compressors in the same cabinet offers hitherto unthinkable FLEXIBILITY AND OPERATIONAL SECURITY. The compressor control range can be as low as 3.8 % of maximum capacity, offering unrivalled flexibility in covering variable consumption.

Easy accessibility

The careful design of NOBEL V allows quick access to its internal components for easy and fast maintenance. The machine can be easily and fully opened on all four sides.

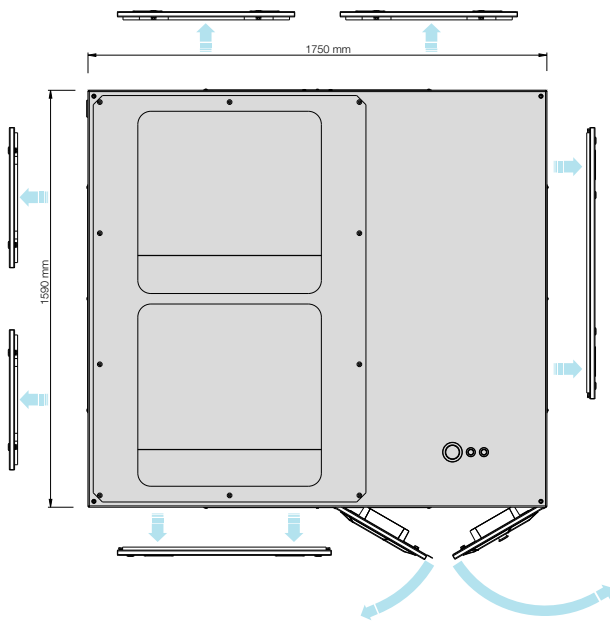

Two motor air-end systems with vertical arrangement

The technical choice of two coupled compressor systems makes it possible to cover a previously unattainable control range: the NOBEL V-TWIN can deliver up to 3.8 % of the maximum flow rate.

Ventilation

Extremely quiet operation due to inverter-controlled radial ventilation, set on operating temperature control.

In the entire TWIN range, the inverter is built into the fan motor.





MAINTENANCE COST SAVINGS

The broad compressor adjustment range allows only one of the two compressors to be active when possible. The ISC function keeps the operating hours of the two machines balanced, lengthening maintenance intervals and thus reducing costs.



Two Login controllers

The Nobel V-TWIN compressors are regulated by two Login electronic controllers, independent in control but connected to each other in 'ISC' (Internal Sequencing of Compressors) mode for the sequencing and rotation of the two systems according to adjustable parameters depending on the compressed air demand.

Two state-of-the-art inverters

The inverters are controlled and monitored via modbus by Login electronic controllers, allowing absolute precision on pressure regulation.

Two separator tanks

The circuits of each system are independent of each other but interconnected thanks to the sequenced control offered by the Login controllers.

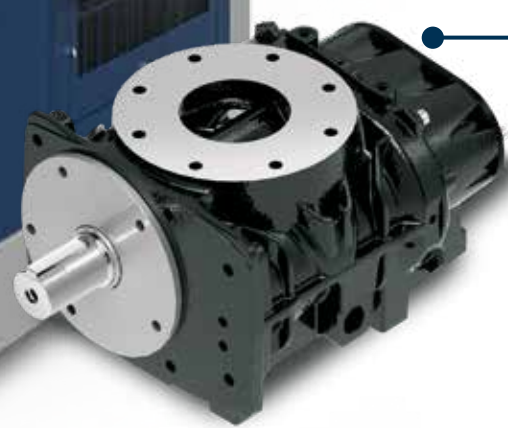

FS270

Highly efficient air-ends of our own production.

NOBEL V 90

NOBEL V - Twin

55-90 kW

Connection bell

It allows quick access for inspection and possible replacement of the flexible coupling.



Direct coaxial 1:1 transmission with vertical set-up

No losses, maximum efficiency.





Independent disconnectable systems

The pneumatic circuits are independent and disconnectable to allow dedicated controls and adjustments.

Dual ventilation system

Extremely quiet operation due to inverter-controlled radial ventilation, set on operating temperature control. On the entire TWIN range the fan inverter is built into the motor itself. The two fans are regulated independently.

Two air filters

Highly efficient intake filter operation with easily accessible and replaceable cartridge.



Two intake regulators

Designed and manufactured by Power System, they guarantee maximum efficiency, low noise and high reliability.

NOBEL V with variable speed, with HDPM permanent magnet synchronous motor

Why choose a compressor with a High Density Permanent Magnet motor?

The energy costs linked to compressor operation can represent more than 80% of the total cost of its life cycle.

Improving the energy efficiency of its products is Power System's main objective, achieved in the Nobel V range through the use of 'HDPM' permanent magnet motors in the IE5 'Super Premium Efficiency' category, combined with our newly developed air-ends.

The design of the air-ends and HDPM motors with vertical arrangement gives the compressors in the NOBEL V series previously unimaginable levels of efficiency.

TWIN versions provide control range coverage from 100% down to 3.8% of the flow rate, effectively zeroing the idle time, saving energy and minimising component wear.

HDPM motors have hitherto unmatched levels of efficiency and minimal heating losses. This allows long bearing life and long maintenance intervals.

Why choose a NOBEL V?

- › HDPM Permanent Magnet Motor with efficiency class IE5.
- › Power System air-ends with vertical arrangement.
- › Coaxial 1:1 transmission.
- › Efficient intake regulator.
- › State-of-the-art inverter.
- › Intuitive touchscreen controller.
- › Low noise levels.
- › High quality components.
- › Low maintenance.



ENERGY EFFICIENCY CLASS
according to IEC standard 60034-30-1

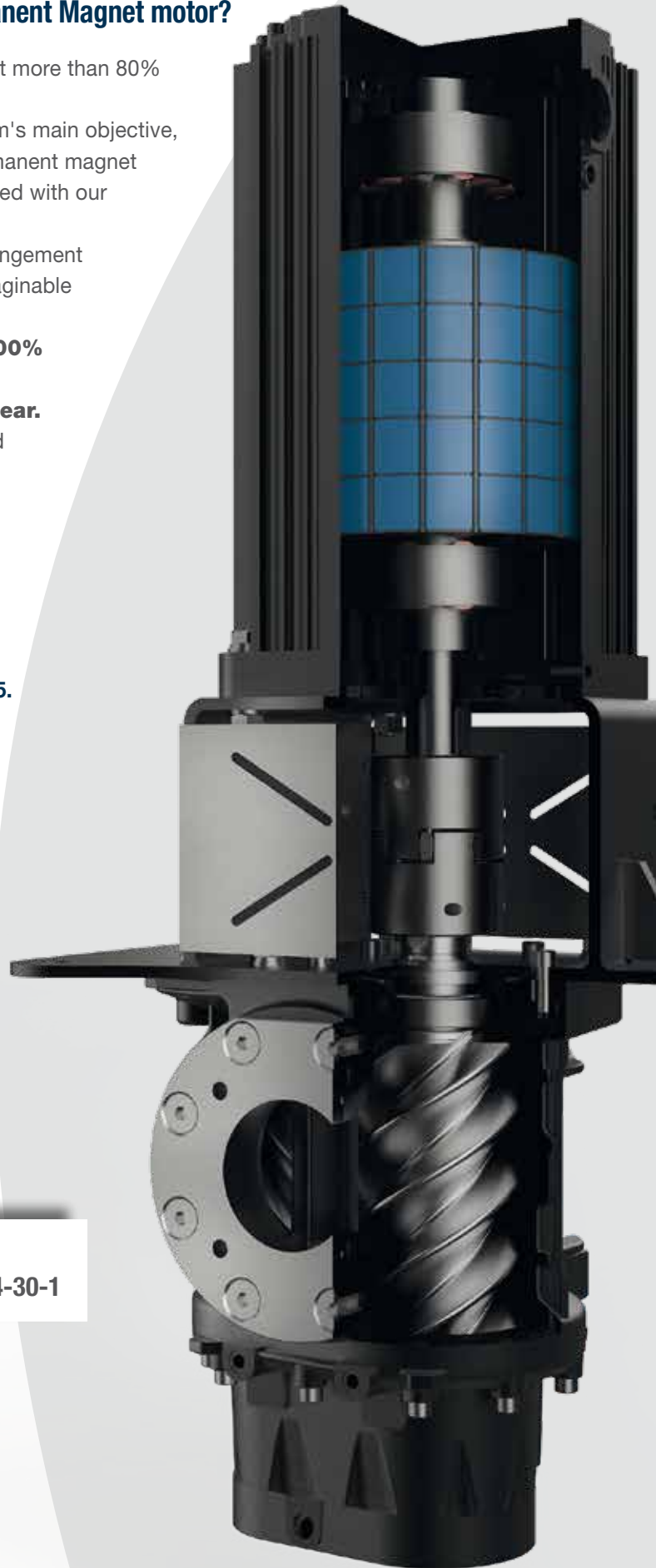

To improve efficiency in every area of compressed air application.

The innovative HDPM Permanent Magnet motors, extremely compact and dynamic, guarantee high performance and much broader speed/flow ranges than traditional inverter-controlled asynchronous motors. **They offer the greatest possible advantages in terms of energy savings, also when used at partial speed, as required ever more frequently in modern and efficient applications.** The NOBEL V TWIN series, from 55 to 90 kW, extends the concept of flexibility, covering a control range from 3.8% to 100% of the total compressor capacity.

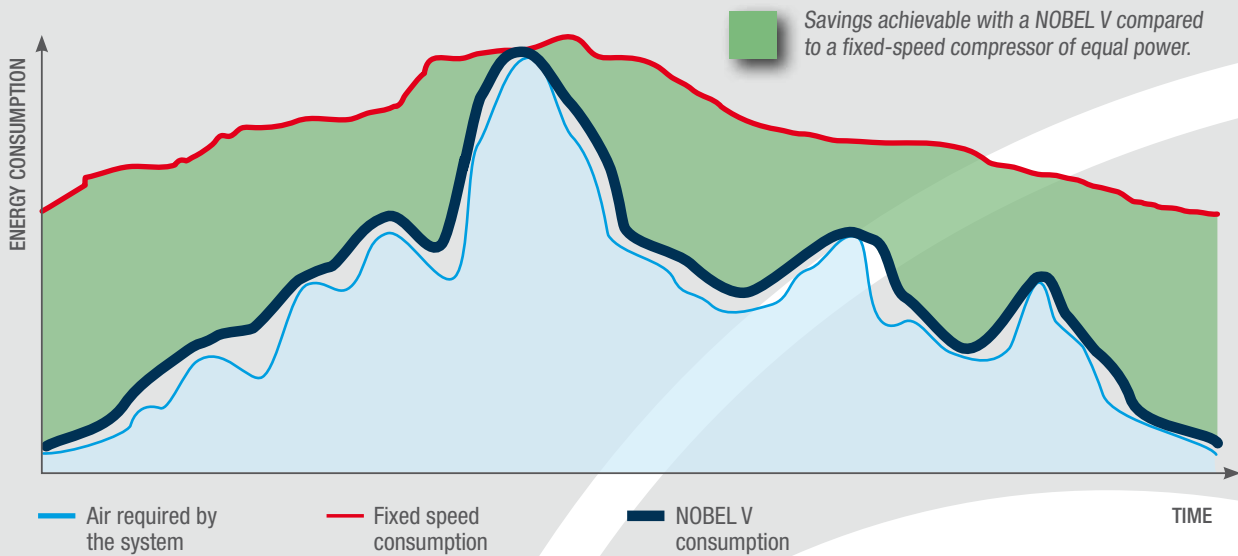

For the variable speed range with HDPM motors, we exclusively use direct transmission with flexible coupling.

The advantages of the NOBEL V range are considerable:

- Production of compressed air according to system demand, achieved by **adjusting the speed of the electric motor from 8% to 100% of maximum speed, going down to 3.8% for TWIN versions.**
- Great stability of operating pressure allowing operation at generally lower levels: this too is energy saving.
- Optimal compressor cooling is achieved through the use of efficient, powerful, inverter-controlled radial fans.
- Proven, highly reliable design.
- Attention to details, to maximise quiet operation and reliability.
- **The best air outflow rates and specific powers on the market.**

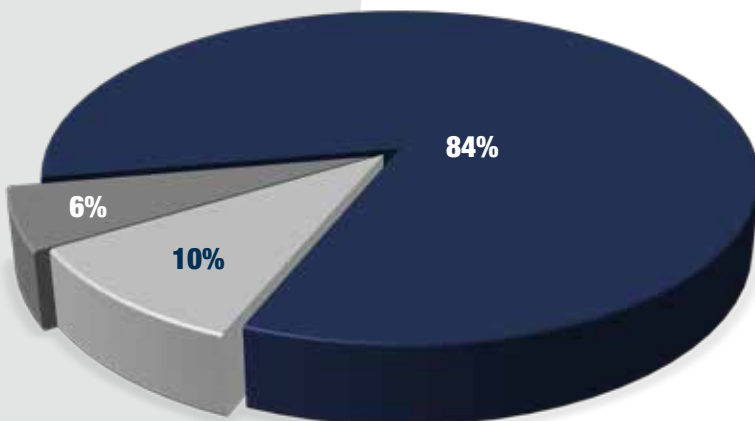

The graph represents the life-cycle cost breakdown of a 37 kW fixed-speed compressor over 5 years of use, assuming 4000 operating hours per year and an energy cost of approximately 0.17 €/kWh.

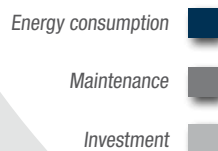

More efficient than ever

The inverter, installed in the compressor's electrical panel, allows dynamic regulation of electric motor and air-end speed, **adjusting the air delivered to the actual demand of the system.**

It also eliminates current surges thanks to the soft start-up and drastically reduces operating cycles in no-load operation, further limiting energy waste and therefore company costs.

In the TWIN versions, larger flow control ranges are achieved with even greater effects on the minimisation of idle running.



Significant energy savings

In comparison to a fixed speed compressor, with a NOBEL V it is possible to achieve significant savings, **up to 50% on energy consumption** and, therefore a reduction of approximately 30% of the cost of the life cycle over 5 years of use.

The calculation shown in the graphs is based on the energy analysis of a 37 kW NOBEL V, assuming 4000 operating hours per year and an energy cost of approximately 0.17 €/kWh.

LIFE CYCLE COST SAVINGS IN 5 YEARS OF A NOBEL V, COMPARED TO A FIXED SPEED COMPRESSOR WITH THE SAME POWER

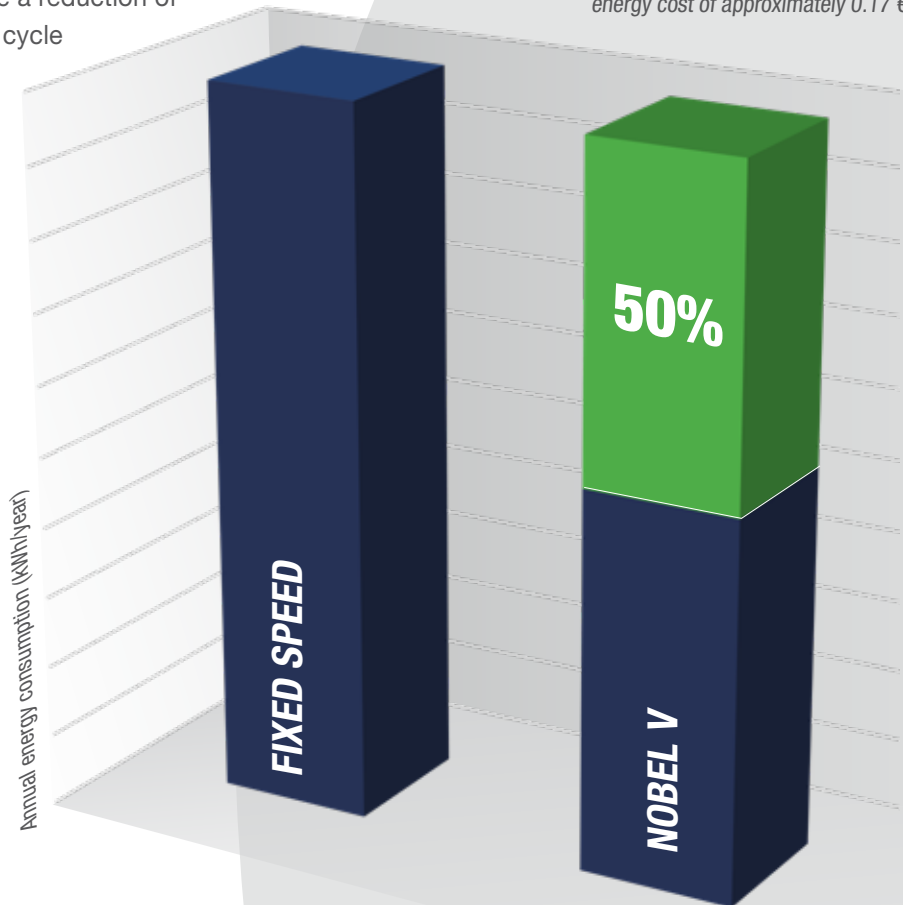
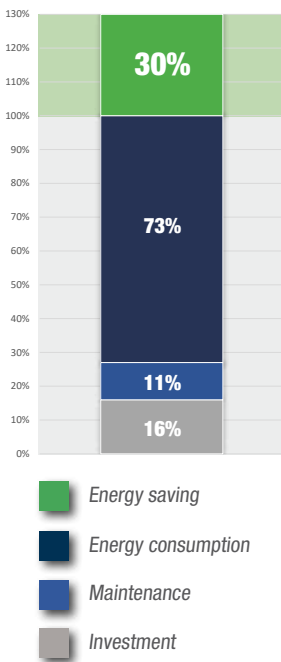

Efficiency is synonymous with sustainability

A company that cares about environmental sustainability must tend to the energy efficiency of its production processes.

Living sustainably means preserving natural resources as much as possible: choosing a NOBEL V, reducing energy consumption and CO₂ emissions, is therefore also an ecological choice.



Power System's mission is to find advanced solutions to compress air with the lowest possible energy consumption, the lowest possible environmental impact and the lowest possible maintenance costs. The choice of components for each Power System compressor follows these objectives.

NOBEL V 18.5-50 kW

| Code | Power | | Air outflow rate (min. - max.) | | | Max. pressure | | Air-end | Sound level | Conne- ction | Net weight | Net dimensions | Gross weight | Gross dimensions |
|------|-------|----|--------------------------------|----------------------|--------|---------------|--------|---------|-------------|-----------------|------------|----------------|--------------|------------------|
| | kW | HP | l/min. | m ³ /min. | c.f.m. | bar | p.s.i. | | | | | | | |

VARIABLE SPEED WITH HDPM PERMANENT MAGNET MOTOR

18.5 kW

| | | | | | | | | | | | | | | | |
|--------------------|---------------|------|----|----------|-----------|--------|----|-----|-------|----|-------|-----|---------------|-----|---------------|
| NOBEL V 18.5-08 PM | V60RO97PWSA87 | 18.5 | 25 | 400-3830 | 0.40-3.83 | 14-135 | 8 | 116 | FS140 | 65 | 1"1/4 | 710 | 1500x750x1920 | 800 | 1700x900x2100 |
| NOBEL V 18.5-10 PM | V60RP97PWSA87 | 18.5 | 25 | 770-3300 | 0.77-3.30 | 27-116 | 10 | 145 | FS140 | 65 | 1"1/4 | 710 | 1500x750x1920 | 800 | 1700x900x2100 |

22 kW

| | | | | | | | | | | | | | | | |
|------------------|---------------|----|----|----------|-----------|--------|----|-----|-------|----|-------|-----|---------------|-----|---------------|
| NOBEL V 22-08 PM | V60RA97PWSA87 | 22 | 30 | 400-4520 | 0.40-4.52 | 14-160 | 8 | 116 | FS140 | 66 | 1"1/4 | 710 | 1500x750x1920 | 800 | 1700x900x2100 |
| NOBEL V 22-10 PM | V60RB97PWSA87 | 22 | 30 | 770-3960 | 0.77-3.96 | 27-140 | 10 | 145 | FS140 | 66 | 1"1/4 | 710 | 1500x750x1920 | 800 | 1700x900x2100 |

26 kW

| | | | | | | | | | | | | | | | |
|------------------|---------------|----|----|----------|-----------|--------|----|-----|-------|----|-------|-----|---------------|-----|---------------|
| NOBEL V 26-08 PM | V60RQ97PWSA87 | 26 | 35 | 400-4950 | 0.40-4.95 | 14-175 | 8 | 116 | FS140 | 66 | 1"1/4 | 710 | 1500x750x1920 | 800 | 1700x900x2100 |
| NOBEL V 26-10 PM | V60RR97PWSA87 | 26 | 35 | 770-4440 | 0.77-4.44 | 27-157 | 10 | 145 | FS140 | 66 | 1"1/4 | 710 | 1500x750x1920 | 800 | 1700x900x2100 |

30 kW

| | | | | | | | | | | | | | | | |
|------------------|---------------|----|----|-----------|-----------|--------|----|-----|-------|----|-------|-----|---------------|------|----------------|
| NOBEL V 30-08 PM | V60RS97PWSA87 | 30 | 40 | 1120-5840 | 1.12-5.84 | 39-206 | 8 | 116 | FS270 | 72 | 1"1/2 | 880 | 1550x820x1970 | 1000 | 1750x1000x2100 |
| NOBEL V 30-10 PM | V60RT97PWSA87 | 30 | 40 | 1120-5270 | 1.12-5.27 | 39-186 | 10 | 145 | FS270 | 72 | 1"1/2 | 880 | 1550x820x1970 | 1000 | 1750x1000x2100 |

37 kW

| | | | | | | | | | | | | | | | |
|------------------|---------------|----|----|-----------|-----------|--------|----|-----|-------|----|-------|-----|---------------|------|----------------|
| NOBEL V 37-08 PM | V60RC97PWSA87 | 37 | 50 | 1120-7200 | 1.12-7.20 | 39-254 | 8 | 116 | FS270 | 72 | 1"1/2 | 880 | 1550x820x1970 | 1000 | 1750x1000x2100 |
| NOBEL V 37-10 PM | V60RD97PWSA87 | 37 | 50 | 1120-6400 | 1.12-6.40 | 39-226 | 10 | 145 | FS270 | 72 | 1"1/2 | 880 | 1550x820x1970 | 1000 | 1750x1000x2100 |

45 kW

| | | | | | | | | | | | | | | | |
|------------------|---------------|----|----|-----------|-----------|--------|----|-----|-------|----|-------|-----|---------------|------|----------------|
| NOBEL V 45-08 PM | V60RE97PWSA87 | 45 | 60 | 1120-8800 | 1.12-8.80 | 39-311 | 8 | 116 | FS270 | 73 | 1"1/2 | 880 | 1550x820x1970 | 1000 | 1750x1000x2100 |
| NOBEL V 45-10 PM | V60RF97PWSA87 | 45 | 60 | 1120-7700 | 1.12-7.70 | 39-272 | 10 | 145 | FS270 | 73 | 1"1/2 | 880 | 1550x820x1970 | 1000 | 1750x1000x2100 |

50 kW

| | | | | | | | | | | | | | | | |
|------------------|---------------|----|----|-----------|-----------|--------|----|-----|-------|----|-------|-----|---------------|------|----------------|
| NOBEL V 50-08 PM | V60RU97PWSA87 | 50 | 68 | 1120-9250 | 1.12-9.25 | 39-327 | 8 | 116 | FS270 | 73 | 1"1/2 | 880 | 1550x820x1970 | 1000 | 1750x1000x2100 |
| NOBEL V 50-10 PM | V60RV97PWSA87 | 50 | 68 | 1120-8040 | 1.12-8.04 | 39-284 | 10 | 145 | FS270 | 73 | 1"1/2 | 880 | 1550x820x1970 | 1000 | 1750x1000x2100 |

NOBEL V TWIN 55-90 kW

| Code | Power | | Air outflow rate (min. - max.) | | | Max. pressure | | Air-end | Sound level | Conne- ction | Net weight | Net dimensions | Gross weight | Gross dimensions |
|------|-------|----|--------------------------------|---------------------|--------|---------------|--------|---------|-------------|-----------------|------------|----------------|--------------|------------------|
| | kW | HP | l/min. | m ³ /min | c.f.m. | bar | p.s.i. | | | | | | | |

VARIABLE SPEED WITH HDPM PERMANENT MAGNET MOTOR

55 kW

| | | | | | | | | | | | | | | | |
|------------------|---------------|----|----|-----------|------------|--------|----|-----|-----------|----|----|------|----------------|------|----------------|
| NOBEL V 55-08 PM | V60RG97PWSA87 | 55 | 75 | 400-10320 | 0.40-10.32 | 14-364 | 8 | 116 | 2 x FS140 | 72 | 2" | 1600 | 1750x1590x1970 | 1790 | 1950x1800x2200 |
| NOBEL V 55-10 PM | V60RH97PWSA87 | 55 | 75 | 770-9400 | 0.77-9.40 | 27-332 | 10 | 145 | 2 x FS140 | 72 | 2" | 1600 | 1750x1590x1970 | 1790 | 1950x1800x2200 |

75 kW

| | | | | | | | | | | | | | | | |
|------------------|---------------|----|-----|------------|------------|--------|----|-----|-----------|----|----|------|----------------|------|----------------|
| NOBEL V 75-08 PM | V60RI97PWSA87 | 75 | 100 | 1120-14400 | 1.12-14.40 | 39-508 | 8 | 116 | 2 x FS270 | 74 | 2" | 1760 | 1750x1590x1970 | 1950 | 1950x1800x2200 |
| NOBEL V 75-10 PM | V60RJ97PWSA87 | 75 | 100 | 1120-12800 | 1.12-12.80 | 39-452 | 10 | 145 | 2 x FS270 | 74 | 2" | 1760 | 1750x1590x1970 | 1950 | 1950x1800x2200 |

90 kW

| | | | | | | | | | | | | | | | |
|------------------|---------------|----|-----|------------|------------|--------|----|-----|-----------|----|----|------|----------------|------|----------------|
| NOBEL V 90-08 PM | V60RM97PWSA87 | 90 | 125 | 1120-17600 | 1.12-17.60 | 39-621 | 8 | 116 | 2 x FS270 | 74 | 2" | 1760 | 1750x1590x1970 | 1950 | 1950x1800x2200 |
| NOBEL V 90-10 PM | V60RN97PWSA87 | 90 | 125 | 1120-15480 | 1.12-15.48 | 39-546 | 10 | 145 | 2 x FS270 | 74 | 2" | 1760 | 1750x1590x1970 | 1950 | 1950x1800x2200 |

Reference conditions: air intake temperature 20°C (68°F) – atmospheric pressure 1 bar (14.5 p.s.i.).

Air flow was measured in the following operating pressure values:

7.5 bar for 8 bar models - 9.5 bar for 10 bar models.

The data and results were measured in accordance with standard ISO 1217.

The sound level was measured according to ISO 2151, with a tolerance of ±3 dB(A).



Efficiency that is always under control

The 'Login' controller introduces new software capabilities to strengthen diagnostic functions, thereby guaranteeing excellent performance in all conditions. Login provides additional features including remote control and multi-compressor management.

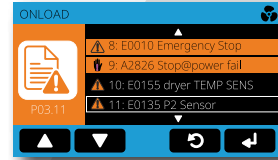
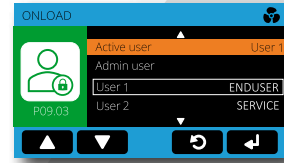
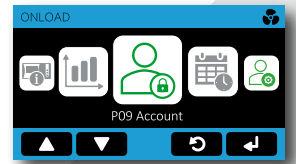

Intelligent control

All of NOBEL's functions are entirely managed by the Login electronic controller, which constantly monitors the compressor status ensuring efficient and reliable operation of the machine in all conditions with customised functions to suit any application.

Always connected

During an irregular event within the machine, Login reports the presence of such and incident by creating an alert for the user, allowing prompt operator intervention. The integrated connectivity with remote monitoring (optional), makes possible to get complete information on the compressor status remotely.

Compressor rotation management

Thanks to the "ISC" system it is possible to simultaneously connect up to 8 different compressors (fixed and/or variable speed combinations), with "master-slave" logic.



Exclusive design

Italian design, functionality, simple to use and with the latest generation technology all come together with the innovative Login controller. The touch-screen display and the icon-based menu make it extremely intuitive and easy to use.



Memory card slot

Login features a memory card slot which can be used to store compressor data and configurations and to transfer them to another control unit.



Multilanguage management

It is possible to select the local language from any of the 20 pre-installed languages.



Remote control

Allows a complete remote monitoring of the compressor.



Multicolour display

All of the operational parameters are displayed on the large 4.3" colour screen which also displays graphs in real time (pressure, power, energy/time).



Designed for Industry 4.0

All of the data that you need

SMS 2.0

SMS 2.0 (Service Management System) is the innovative device (optional) to remotely access and perform preventive maintenance checks on any of the screw compressors fitted with a LOGIN controller.

Preventive and targeted maintenance

Through a LAN connection with Ethernet cable, SMS 2.0 allows e-mails to be sent automatically should an irregular event occur (up to 5 settable e-mail addresses).

At the same time, it is possible to monitor the correct operation of the compressor and to check the scheduling for future maintenance interventions.

SMS 2.0 is installed directly on the Login controller, at the rear.

CODE C005560002SGL

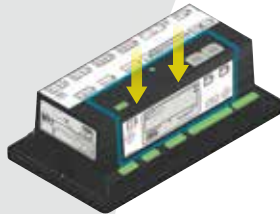

Compressor remote control:

- online compressor status control (view of temperature and pressure parameters);
- on/off control;
- view of events and alarms;
- view of remaining hours to maintenance;
- graphic view of analogue signals connected to the controller, in real time;
- no additional software is needed.



Extend the life and efficiency of your screw compressor.

In addition to offering the highest quality and technologically advanced products, Power System focuses its attention on customer care and full technical and product support, identifying our customers' needs and the most suitable solutions.

Our skilled and professional team grants assistance over the phone/email, technical on-site consultancy, personalised quotations, maintenance programs, training programmes, etc.

The importance of original spare parts...

FSN is the brand of the original spare parts and after sales activities for all Power System compressors. FSN guarantees that the components are original and that they were carefully selected, checked and tested by skilled technicians. Using FSN certified original spare parts reduces management costs and guarantees the efficiency, reliability and longevity of the compressor. Our "Hot-Line" service guarantees the shipment of urgent spare parts within twenty-four hours from the order.

Long Life Kit: for the scheduled maintenance of screw compressors

To make maintenance planning simple and in accordance with the recommendations, Power System has developed its "LONG LIFE SERVICE KITS", specifically created for all Power System screw compressor models.

Using Long Life Kits ensures an extended service life, increased safety whilst ensuring maximum compressor performance.



Investment guaranteed up to 5 years! with the TRUST warranty extension

Power System believes so strongly in the quality and reliability of its compressors that we guarantee them for up to FIVE years! By choosing Trust it is possible to extend the standard warranty period by 3 or 5 years, through a complete preventive maintenance program.

There are many benefits: the customer can thereby avail of the qualified assistance of authorised technicians in complete safety, reducing the uncertainty of maintenance costs and foreseeing any downtime. Also, the use of original spare parts guaranteed by the FSN trademark will ensure that the compressor operates with maximum efficiency and for a longer service life.

The "Trust" warranty can be easily extended online through EasyConnect, the new Power System service portal.



...and specific lubricants:

RotarECOFLUID 46 cSt mineral oil

| | |
|-------------------|-----------------------------|
| C600000020 | 1 x 3.8-litre can (3.3 kg) |
| C600000021 | 1 x 20-litre can (17.36 kg) |
| C600000022 | 1 x 200-litre drum (174 kg) |

Formulated with high quality selected mineral oil, this lubricant offers optimal control of oxidation and residue deposits as well as an excellent level of thermal stability and oxidation to ensure the longevity of equipment and continued high performance.

RotEnergyPlus 46 cSt synthetic oil

| | |
|--------------------|-----------------------------|
| C600000018A | 1 x 3.8-litre can (3.25 kg) |
| C600000007A | 1 x 19-litre can (16 kg) |
| C600000012A | 1 x 208-litre drum (181 kg) |

Ensures quick water separation with reduced friction and energy consumption, provides long maintenance intervals and ensures excellent lubrication of the bearings while offering an excellent protection throughout.

RotEnergyFood 46 cSt synthetic oil

| | |
|--------------------|-----------------------------|
| C600000019A | 1 x 3.9-litre can (3.25 kg) |
| C600000016A | 1 x 19-litre can (18.5 kg) |
| C600000017A | 1 x 208-litre drum (175 kg) |

A high quality lubricant for rotary compressors, suitable for use in the food industry, where specific quality standards are required.

Our FSN mineral or synthetic based lubricants are specifically designed for use on our screw compressors. They are available in cans or drums in various sizes.

We recommend replacing the oil according to the interval reported in the handbook / maintenance manual of the compressor or once a year if sooner. We recommend using our original RotarECOFLUID mineral oils, or RotEnergyPlus and RotEnergyFood synthetic oils (OILS ARE NOT INCLUDED IN LONG LIFE KITS).



FSN
ORIGINAL SPARE PARTS

You can download the Long Life Kit catalogues from www.powersystem.it and see the exploded diagrams and spare parts list online. These are continuously updated for each compressor model.

FNA S.p.A. Via Einaudi, 6
10070 Robassomero Torino ITALY
T: +39 011 92 33 000 F: +39 011 92 41 138

BOLOGNA PLANT:
Via Toscana, 21 40069 Zola Predosa Bologna ITALY
T: +39 051 61 68 111 F: +39 051 75 24 08
info@fnacompressors.com
www.fnacompressors.com



a brand of



AUTHORIZED DISTRIBUTOR:

Follow us on: [LinkedIn](#)



powersystem.it

